

| ITEM NO. | QTY. | PART NO. | DESCRIPTION |
|----------|------|----------------|---|
| 1 | 1 | 668962 | 2 SPOOL LOAD SENSING VALVE |
| 2 | 1 | 683152 | KIT-JOYSTICK BENT 59" 2 SP |
| 3 | 1 | 672858 | COUPLER PLATE |
| 4 | 1 | 676424 | VALVE PLATE |
| 5 | 1 | 689591 | VALVE BRACKET |
| 6 | 1 | 691620 | JOHN DEERE JOYSTICK MOUNT KIT |
| 7 | 1 | 693699 | POWER BEYOND BLOCK ASSEMBLY |
| 8 | 2 | 669298 | CABLE CONNECTOR KIT |
| 9 | 1 | 673956 | COLOR COUPLER PLUG KIT |
| 10 | 4 | 673740 | QUICK COUPLER BULKHEAD SET |
| 11 | 3 | 672503 | OIL LINE CLAMP TWIN .500 |
| 12 | 2 | 669686 | 36" HOSE WRAP |
| 13 | 5 | 652393 | 14.25 NYLON CABLE TIE |
| 14 | 1 | 674250 | DIME DISK |
| 15 | 4 | 6400-8-10 | FITTING - HYD ADA 8MJX - 10ORM |
| 16 | 2 | 6801-10-10 | FITTING - HYD ELB 90 10MJX-10ORM |
| 17 | 1 | 6801-6-6 | FITTING-HYD ELB 90 6MJX-6MOR |
| 18 | 1 | 6MJIC14MM1.5 | FITTING - HYD ADA 6MJX-14MM-1.5P O-RING |
| 19 | 1 | 6410-10-6 | FITTING - ADA 10ORM - 6ORF |
| 20 | 2 | 10MJIC-22MM1.5 | FITTING - HYD ADA 10MJX-22MM-1.5P |
| 21 | 4 | 676925 | HOSE - HYD .500-30 8FJX-8FJX90 |
| 22 | 2 | 676921 | HYD HOSE .625-84 10FJX-10FJX45 |
| 23 | 1 | 676922 | HYD HOSE .375-84 6FJX-6FJX45 |
| 24 | 4 | 676988 | HYD HOSE .5-84 8ORM-8MJX |
| 25 | 3 | 676901 | SCREW-M10-1.0 X 175MM STUD |
| 26 | 3 | 676902 | SCREW-M10-1.0 X 225MM STUD |
| 27 | 2 | 640059 | SCREW-.50-13 X 1.50 GR 5 HHC |
| 28 | 2 | 683932 | NUT - .50 X 13 FLANGE |
| 29 | 2 | 640159 | WASHER - 5/8" SPRING LOCK |
| 30 | 2 | 652048 | WASHER - 5/8" FLAT N-SERIES |
| 31 | 2 | 651717 | WASHER - 14MM SPRING LOCK |
| 32 | 2 | 640114 | SCREW - 14MM - 2.0 X 45 GR 8.8 HHC |
| 33 | 2 | 656016 | SCREW - 16MM - 2.0 X 50 GR 10.9 HHC |
| 34 | 7 | 640032 | SCREW-.375-16 X 1.25 GR 5 HHC |
| 35 | 7 | 682413 | NUT - .375 X 16 FLANGE |
| 36 | 2 | 640154 | WASHER - 3/8" FLAT |
| 37 | 1 | 640046 | SCREW-.375-16 X 4.00 GR 5 HHC |
| 38 | 1 | 700560 | NUT - .375-16 GR 2 CENTER LOCK |

NOTE:

- REFER TO WRITTEN INSTRUCTIONS ON ADDITIONAL INFORMATION TO INSTALL KIT.
- USE HOSE WRAP AND NYLON TIES TO SECURE HOSES TOGETHER.

2 SPOOL PLUMBING KIT #690140

JOHN DEERE 6615-6715-7220-7320-7420-7520

INSTALLATION INSTRUCTIONS:

1. Mount kit should be installed before proceeding to ensure that there is no interference.
2. First, attach spacer block kit (Part #7) using (#676901 or #676902) (Part #25 & 26) to tractor. **See in Fig. 1-1.** If there are two rear remotes you will require (Part #676901) short studs (Part #25)

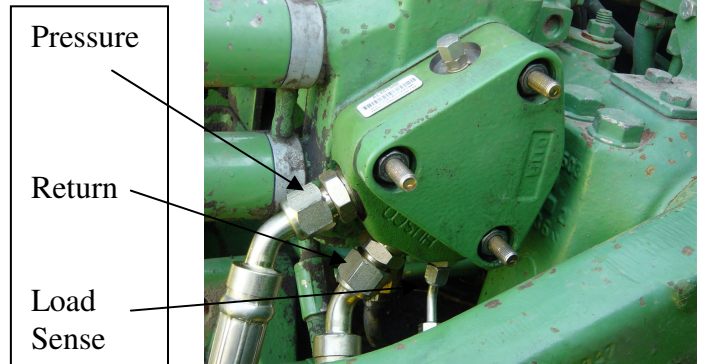

and use the long stud (Part #676902) (Part #26) if you have three rear remotes. Make sure that you add the dime disk (Part #14).

3. Once that has been done attach the valve plate (Part #4) onto the RH side of the tractor behind the rear mount. Secure with two 14mm – 2.0 P x 45mm HH cap screws, flatwashers and lock washers (Part #32, 30 & 31) or 16mm – 2.0 P x 50mm HH cap screws, flatwashers and lock washers (Part #33, 29 & 30). **See in Fig. 1-2.**
4. Install seven adapters (Part #15, 16, 19 and 17) into the pressure, return, load sense and all the working ports on the top of the valve. **TIGHTEN ALL THE CONNECTIONS SECURELY!**
5. Install the valve (Part #1) onto the valve plate with four 3/8" x 1 1/4" HH cap screws, and flange nuts (Part #35 & 36).

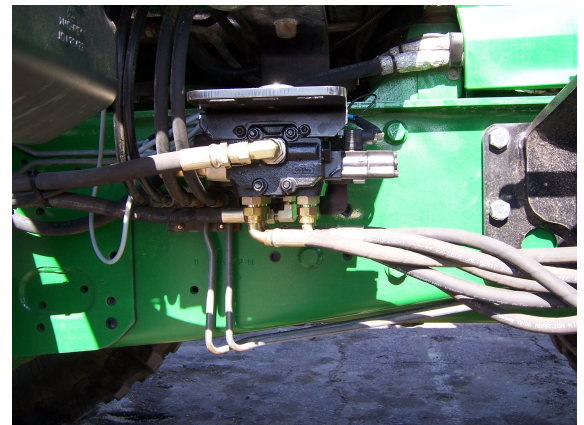

6. Next, install the joystick mount kit (Part #6). Refer to the instruction sheet for this kit. **See in Fig. 1-3.**
7. **Note:** The locking tab on the joystick base has to face to the rear of the tractor. If joystick needs a 1/4 turn remove the two metal sleeves for the bolts from joystick base and reinsert them at a 1/4 turn.
8. There are removable plugs in the cab floor just ahead of the side console to route the cable ends down through the floor to the valve. Adjust the bracket to acquire the most desirable position for the joystick handle. **See in Fig. 1-3 and Fig 1-4.**
9. When this has been done attach the cable ends to the valve body with the connector kits (Part #8). **Note: Make sure the joystick is in the locked position.** (Center the joystick and push the joystick tab in (located on the side of joystick) to lock joystick.) First screw the large nut on to the cable past the threads. Now



Fig 1-3

Fig 1-1

slide the small O-ring on the cable past the threads. Slide the lock ring on the connector and thread the cable connector past the threads. Now thread the small nut and the pin connector onto the cable and tighten together. Slide large O-ring on to the connector. Now push pin connector onto the valve push rod and slide the solid pin through the aligned holes. Thread the cable connector to the valve by hand. **Note: Only hand tighten the valve connector, if over tightened the joystick will not be centered.** Now slide large O-ring onto the valve into the groove of cable connector. Then slide the valve connector lock ring to the valve and bolt together with given Allen head bolts. Slide the small o-ring to cable connector groove on the end and thread the large nut to cable connector and tighten.



Fig 1-4

Note: Make sure the cable connector does not move. See in Fig. 1-5.

10. Route the 84" hoses (Part #22 & 23) underneath the tractor cab and attach to the proper ports on the manifold block already installed on the back of the tractor. See instruction sheet for proper connections.
11. Next, attach the quick coupler with bulkhead (Part #10) onto the mid-mount coupler plate (Part #3). **Note:** At this point, install the male half of the colored plugs (Part #9) onto the female couplers.
12. Now attach the mid-mount couple plate (Part #3) with female couplers installed to the upright valve bracket (Part #5) with two 3/8" x 1 1/4" HH cap screws, and flange nuts (Part #34 & 35) and attach this to the mount upright with two 1/2" x 1 1/2" HH cap screws and 1/2" flange nuts. (Part #27 & 28).

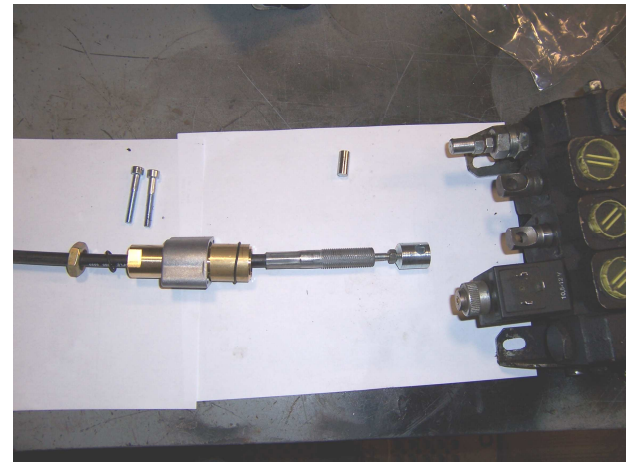

Fig 1-5

See in Fig. 1-6.

13. Run the four hydraulic hoses (Part #21) from valve to mid-mount couplers.
14. After this has been done attach the male half of the quick coupler (Part #10) onto the 84" loader hoses (Part #24). **Note:** At this point, install the female half of the colored plugs (Part #9). Attach the male end to the female coupler. Attach the other end of the hoses to the steel oil lines on the loader frame. Refer to the top view of the working port diagram and the loader manual to determine the function of the port.
15. Using 4 of the plastic oil line clamps (Part #11) stack the hyd hoses from the coupler plate to the steel loader lines using one 3/8" x 5" HH cap screw, flat washers, and lock nut (Part #37, 36, & 38). **See Fig. 1-7.**
16. Secure hoses together with the 36" of hose wrap and nylon ties to make sure they do not interfere with any tractor function.
17. Finally start the tractor, actuate the loader to charge the hydraulic system with oil and add hydraulic fluid to the tractor as required using the recommended fluid for your tractor. Refer to the hydraulic section of the tractor owner's manual for the



Fig 1-6

specific details regarding hydraulic fluid levels.



Fig 1-7

2 SPOOL LOAD SENSING/CLOSED CENTER VALVE
PORTS LABELED

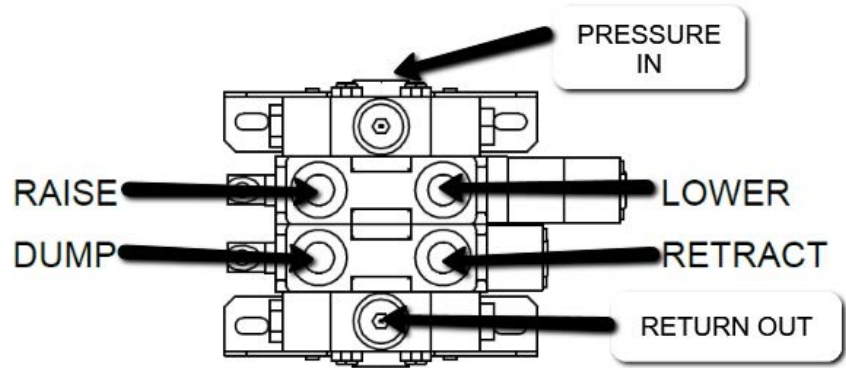

LOAD SENSE IN /
PLUG FOR CLOSED
CENTER

3 SPOOL LOAD SENSING/CLOSED CENTER
VALVE PORTS LABELED

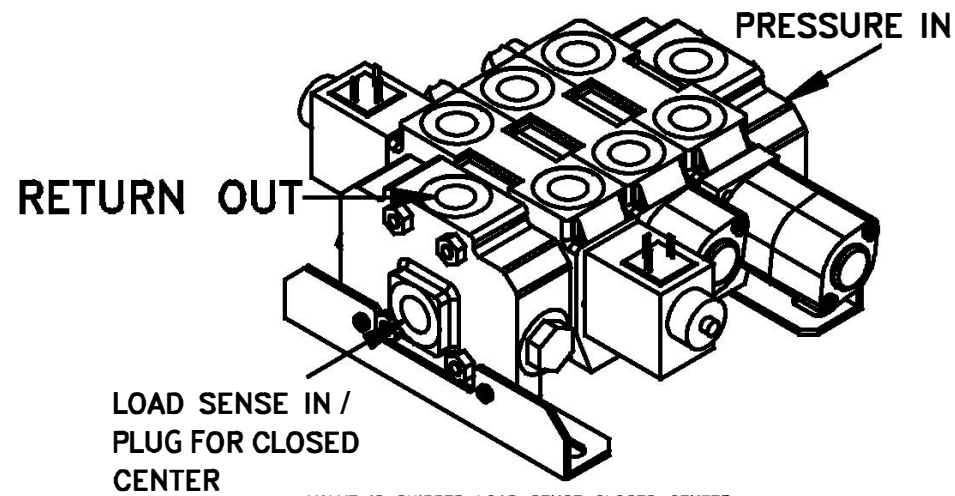
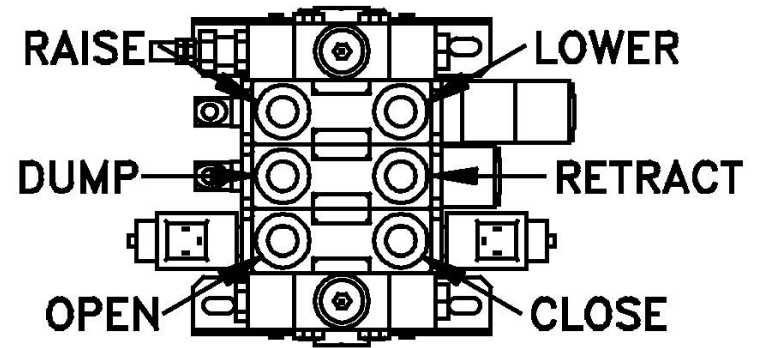

VALVE IS SHIPPED LOAD SENSE CLOSED CENTER.

VIDEOS:

CONNECTING CABLES TO VALVE:

<https://youtu.be/AOKy1CnuU4o>



CONNECTING CABLES TO JOYSTICK:

<https://youtu.be/vbcYCtpPtaw>

