

USE PLUGS ON COUPLERS WHEN DISCONNECTED. ATTACH OVER HOSE ENDS DURING INSTALLATION.

NOTE:
1. REFER TO WRITTEN INSTRUCTIONS ON ADDITIONAL INFORMATION TO INSTALL KIT.
2. USE HOSE WRAP AND NYLON TIES TO SECURE HOSES TOGETHER.

ITEM NO.	QTY.	PART NO.	DESCRIPTION
1	1	668962	2 SPOOL LOAD SENSING VALVE
2	1	683152	KIT-JOYSTICK BENT 59" 2 SP
3	1	672858	COUPLER PLATE
4	1	676424	VALVE PLATE
5	1	691620	JOHN DEERE JOYSTICK MOUNT KIT
6	1	689591	VALVE BRACKET
7	1	685383	POWER BEYOND BLOCK
8	2	669298	CABLE CONNECTOR KIT
9	1	673956	COLOR COUPLER PLUG KIT
10	4	673740	QUICK COUPLER BULKHEAD SET
11	3	672503	OIL LINE CLAMP TWIN .500
12	2	669686	36" HOSE WRAP
13	5	652393	14.25 NYLON CABLE TIE
14	4	6400-8-10	FITTING - HYD ADA 8MJX - 10ORM
15	2	6801-10-10	FITTING - HYD ELB 90 10MJX-10ORM
16	1	6801-6-6	FIITTING-HYD ELB 90 6MJX-6MOR
17	1	6MJIC-14MM1.5	FITTING - HYD ADA 6MJX-14MM-1.5P O-RING
18	1	6410-10-6	FITTING - ADA 10ORM - 6ORF
19	2	10MJIC-22MM1.5	FITTING - HYD ADA 10MJX-22MM-1.5P
20	4	676925	HOSE - HYD .500-30 8FJX-8FJX90
21	2	676921	HYD HOSE .625-84 10FJX-10FJX45
22	1	676922	HYD HOSE .375-84 6FJX-6FJX45
23	4	676988	HYD HOSE .5-84 8ORM-8MJX
24	2	640059	SCREW-.50-13 X 1.50 GR 5 HHC
25	2	683932	NUT - .50 X 13 FLANGE
26	2	640159	WASHER - 5/8" SPRING LOCK
27	2	652048	WASHER - 5/8" FLAT N-SERIES
28	2	651717	WASHER - 14MM SPRING LOCK
29	2	640114	SCREW - 14MM - 2.0 X 45 GR 8.8 HHC
30	2	656016	SCREW - 16MM - 2.0 X 50 GR 10.9 HHC
31	7	640032	SCREW-.375-16 X 1.25 GR 5 HHC
32	7	682413	NUT - .375 X 16 FLANGE
33	3	685384	STUD - 142.5MM
34	2	640154	WASHER - 3/8" FLAT
35	1	640046	SCREW-.375-16 X 4.00 GR 5 HHC
36	1	700560	NUT - .375-16 GR 2 CENTER LOCK

SHORT LINE PARTS
WWW.SHORTLINEPARTS.COM
SALES@SHORTLINEPARTS.COM

JOHN DEERE 7130-7230-7330-7430-7530

INSTALLATION INSTRUCTIONS:

1. Mount kit should be installed before proceeding to ensure that there is no interference.
2. First, attach power beyond block kit (Part #7) using longer studs (Part #33) to right hand side valve stack. **See in Fig. 1-1.** Once that has been done attach the valve plate (Part #4) onto the RH side of the tractor behind the rear mount. Secure with two 14mm – 2.0 P x 45mm HH cap screws, flat washers and lock washers (Part #29, 27 & 28) or 16mm – 2.0 P x 50mm HH cap screws, flat washers and lock washers (Part #30, 26 & 27). **See in Fig. 1-2.**

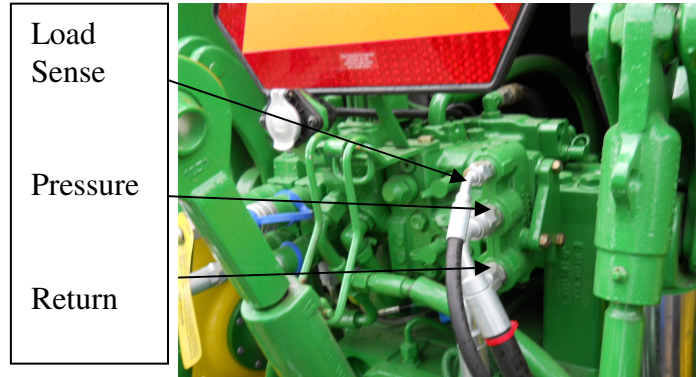

Fig 1-1

3. Install seven adapters (Part #14, 15, 18 and 16) into the pressure, return, load sense and all the working ports on the top of the valve. **TIGHTEN ALL THE CONNECTIONS SECURELY!**
4. Install the valve (Part #1) onto the valve plate with four 3/8” x 1 1/4” HH cap screws, and flange nuts (Part #31 & 32).
5. Install the joystick mount kit (Part #5) at this time. Refer to the instruction sheet for this kit. **Note:** The locking tab on the base of the joystick has to face to the rear of the tractor, if joystick needs a 1/4, turn, remove the two metal sleeves for the bolts from joystick and reinsert them at a 1/4 turn.
6. There are removable plugs in the cab floor just ahead of the side console to route the cable ends down to the valve. Adjust the bracket to acquire the most desirable position for the joystick handle. **See in Fig. 1-3 and Fig 1-4.**

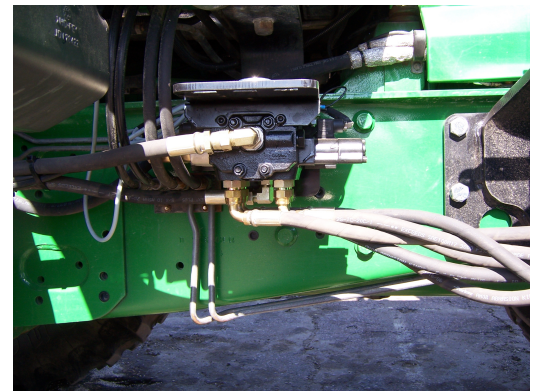

Fig 1-2

7. When this has been done attach the cable ends to the valve body with the connector kits (Part #8). **Note: Make sure the joystick is in the locked position.** (Center the joystick, and push the joystick locking tab in (located on the side of joystick) to lock joystick.). First, screw the large nut on to the cable past the threads. Then slide the small o-ring on the cable past the threads. Now thread the small nut and the pin connector onto the cable and tighten. Slide large o-ring onto the connector. Slide the valve connector on the cable. Now push pin connector onto the valve push rod and slide the pin through the aligned holes. Thread the cable connector to the valve by hand holding the pin in place. **Note: Only hand tighten the valve connector, if over tightened the joystick will not be correct.** Now push large o-ring to the valve into



Fig 1-3

the groove of cable connector. Then slide the valve connector to the valve and bolt together with given Allen head bolts. Slide the small o-ring to cable connector groove on the end and thread the large nut to cable connector and tighten. **Note: Make sure the cable connector does not move. See in Fig. 1-5.**



Fig 1-4

8. Route the three 84” hoses (Part #21 & 22) underneath the tractor cab and attach to the proper ports on the manifold block already installed on the back of the tractor. See instruction sheet for proper connections.

9. Next, put the female quick coupler with bulkhead (Part #10) on the mid-mount couple plate (Part #3). **Note:** At this point, install the male half of the colored plugs (Part #9) onto the couplers.

10. Now install the mid-mount couple plate (Part #3) to the upright valve bracket (Part #6) with two 3/8” x 1 1/4” HH cap screws and flange nuts (Part #31 & 32). Then attach the upright bracket (Part #6) to the loader upright with two 1/2” X 1 1/2” HH cap screws and flange nuts (Part #24 & 25).

11. Run the four 30” hydraulic hoses (Part #20) from valve to mid-mount coupler.

12. After this has been done attach the male half of the quick coupler (Part #10) onto the 84” hoses (Part #23). **Note:** At this point, install the female half of the colored plugs (Part #9). Attach male end to female coupler. Attach the other end of the hoses to the steel oil lines on the loader. Refer to the top view of the working port diagram and the loader manual to determine the function of the port.

13. Using 3 of the plastic oil clamps (Part #11) stack the hyd hoses from the coupler plate to the steel loader lines using one 3/8” X 4” HH cap screw, 2 flat washers and a lock nut (Part #35, 34, and 36). **See Fig. 1-6.**

14. Secure hoses together with the 36” of hose wrap and nylon ties to make sure they do not interfere with any tractor function.

15. Finally start the tractor, actuate the loader to charge the hydraulic system with oil and add hydraulic fluid to the tractor as required using the recommended fluid for your tractor. Refer to the hydraulic section of the tractor owner’s manual for the specific details regarding hydraulic fluid levels.

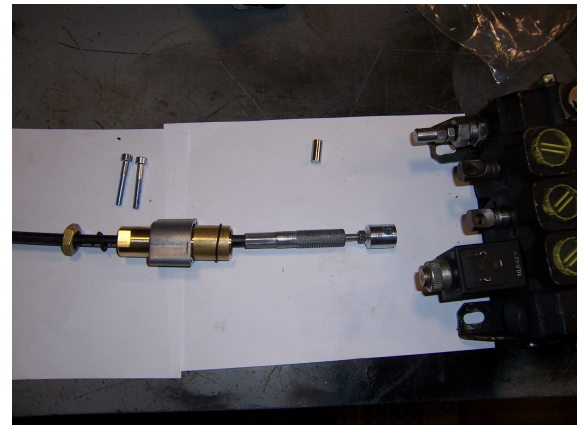

Fig 1-5



Fig 1-6



2 SPOOL LOAD SENSING/CLOSED CENTER VALVE
PORTS LABELED

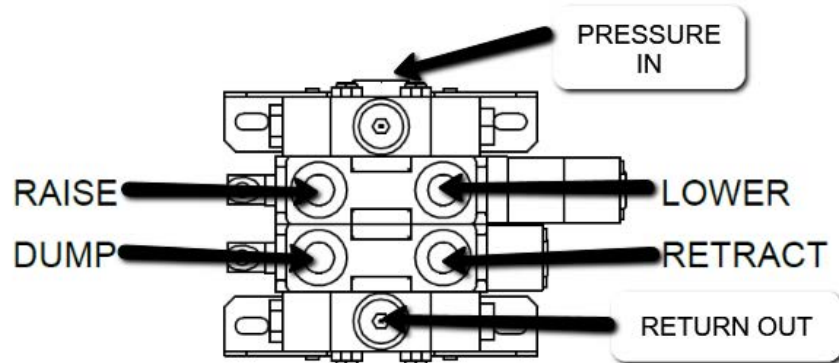

LOAD SENSE IN /
PLUG FOR CLOSED
CENTER

3 SPOOL LOAD SENSING/CLOSED CENTER
VALVE PORTS LABELED

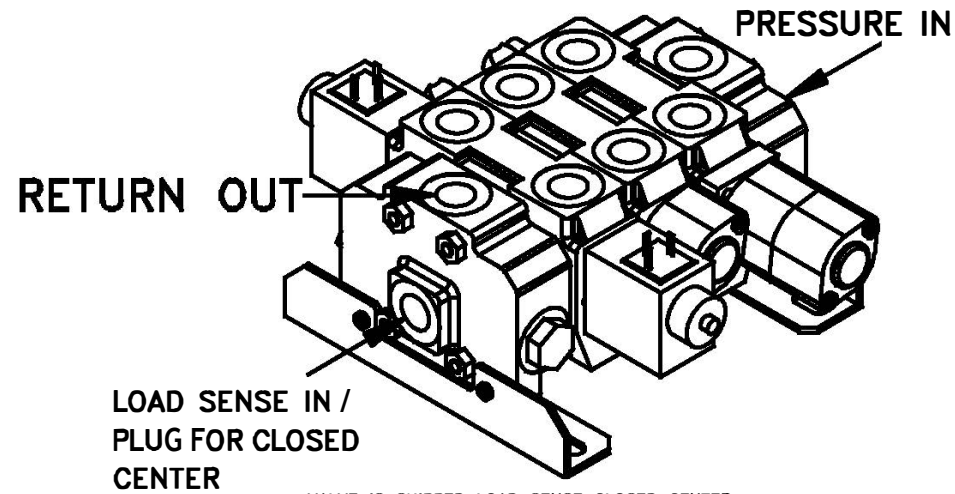
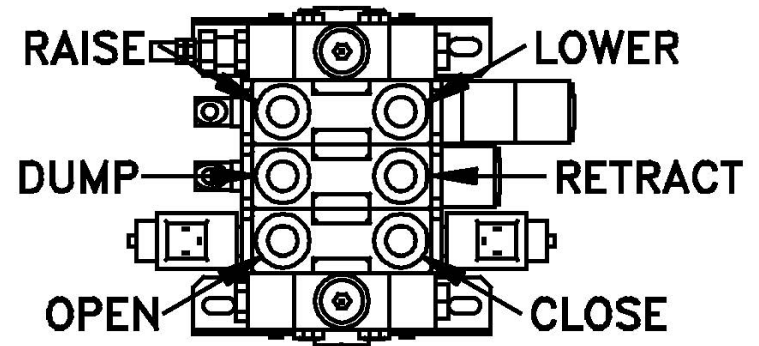

VALVE IS SHIPPED LOAD SENSE CLOSED CENTER.

VIDEOS:

CONNECTING CABLES TO VALVE:

<https://youtu.be/AOKy1CnuU4o>



CONNECTING CABLES TO JOYSTICK:

<https://youtu.be/vbcYCtpPtaw>



COMPLETE JOYSTICK KIT INSTALLED ON
JD 7130:

<https://youtu.be/JdWkNpW4TTs>

