

680326 2 SPOOL PLUMBING KIT FOR JOHN DEERE 2940-2950-2955-3055-3130-3140-3150-3155-3255

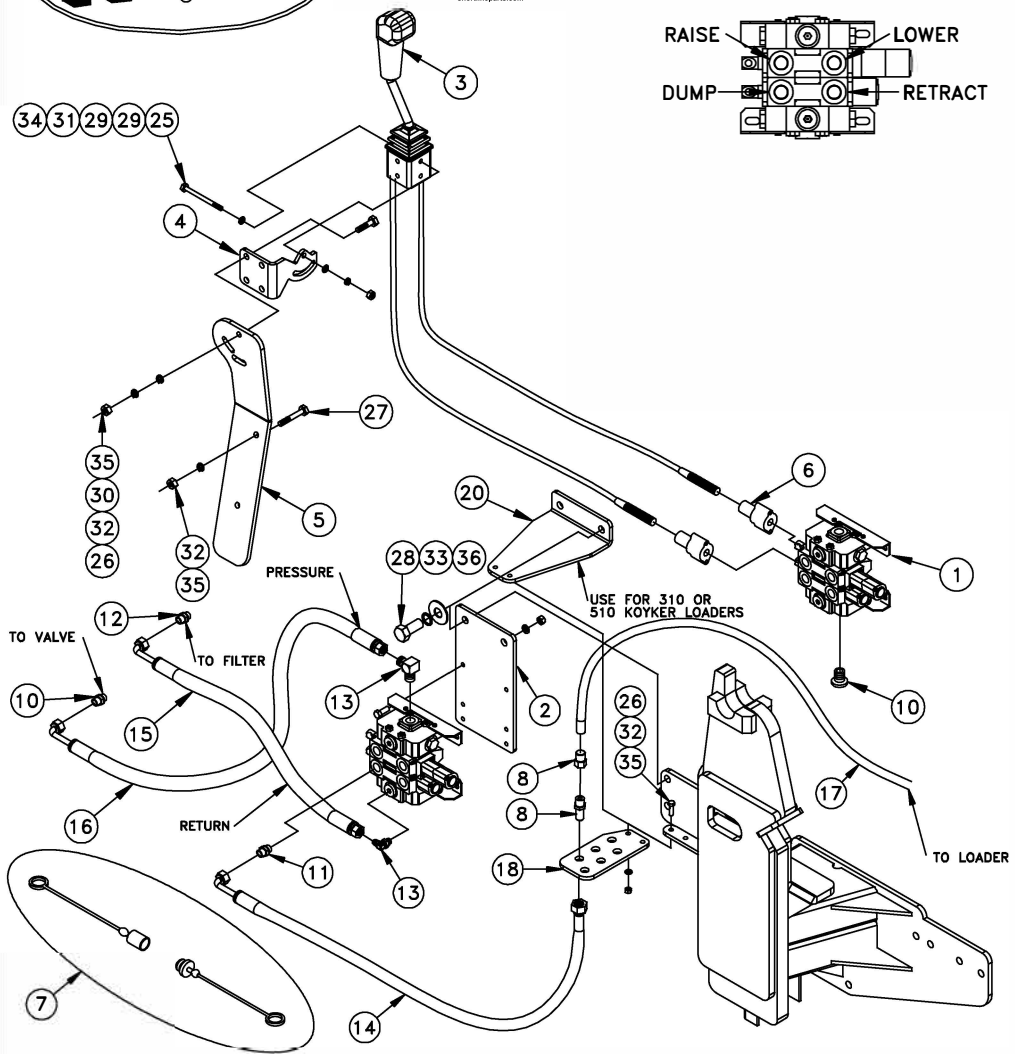

TOP VIEW OF WORKING PORTS ON THE VALVE

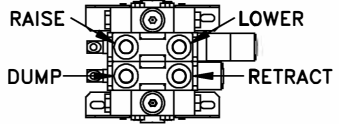

KEY	PART NO.	DESCRIPTION	QTY.
1	668962	2 SPOOL VALVE (LOAD SENSE)	1
2	680328	VALVE PLATE	1
3	683154	JOYSTICK CABLE CONTROL KIT W/78" CABLES	1
4	684725	JOYSTICK HANDLE BRACKET	1
5	669899	HANDLE BRACKET ADAPTER PLATE	1
6	669298	CABLE CONNECTOR KIT	2
7	673956	COLOR COUPLER PLUG KIT	1
8	673740	QUICK COUPLER SET; -8 O-RING	4
9	6408-10	FITTING; PLUG 10 O-RING MALE	1
10	6MJIC-14MM1.5	ADAPTER; -6 MJIC x 14MM x 1.5P MALE	1
11	6400-8-10	ADAPTER; -8 MJIC x -10 ORM	4
12	6400-8-12	ADAPTER; -8 MJIC x -12 ORM	1
13	6801-8-10	90° ELBOW; -8 MJIC x -10ORM	2
14	676925	30" HYDRAULIC HOSE	4
15	675512	48" HYDRAULIC HOSE (RETURN)	1
16	659306	58" HYDRAULIC HOSE (PRESSURE)	1
17	673909	72" HYDRAULIC HOSE	4
18	672858	COUPLER PLATE	1
19	680331	COUPLE PLATE (310 OR 510 LOADER)	1
	669686	36" HOSE WRAP	1
	652393	NYLON TIE	5
	663708	JOYSTICK DECAL	1
	#345	HARDWARE BAG	1
25	669618	HH CAP SCREW; 5/16" x 3 1/2"	2
26	640032	HH CAP SCREW; 3/8" x 1 1/4"	9
27	673012	HH CAP SCREW; 3/8" x 1 3/4"	2
28	640079	HH CAP SCREW; 5/8" x 2"	2
29	640152	FLATWASHER; 5/16"	4
30	640154	FLATWASHER; 3/8"	2
31	640151	LOCKWASHER; 5/16"	2
32	640153	LOCKWASHER; 3/8"	9
33	640159	LOCKWASHER; 5/8"	2
34	652360	HEXNUT; 5/16"	2
35	640132	HEXNUT; 3/8"	9
36	640142	HEXNUT; 5/8"	2

NOTE: 1. BEFORE INSTALLING KIT ATTACH LOADER MOUNT FIRST. REFER TO THE INSTRUCTIONS PROVIDED WITH THAT KIT.
 2. REFER TO WRITTEN INSTRUCTIONS ON ADDITIONAL INFORMATION TO INSTALL KIT.
 3. USE HOSE WRAP AND NYLON TIE TO SECURE HOSES TOGETHER.

Short Line Parts, LLC
 www.shortlineparts.com
 605-951-0167



2 SPOOL PLUMBING KIT #680326

JOHN DEERE 2940-2950-2955-3055-3130-3130-3140-3150-3155-3255

INSTALLATION INSTRUCTIONS:

1. First install the mount kit on the tractor (See mount instructions).
2. Once that has been done attach the valve plate (Part #2) onto the RH side of the tractor behind the rear mount. **See Fig 1-1.** Secure with two 5/8" x 1 3/4" HH cap screws, lockwashers and flatwashers (Part #28, 33 & 36). If you have 310 or 510 loader use the couple mount (Part #19).
3. Install plug (Part #10) into this port. Then install eight adapters (Part #11 & 13) into the pressure, return and all the working ports on the top of the valve. **TIGHTEN ALL THE CONNECTIONS SECURELY!**
4. Install the valve (Part 1) onto the valve plate with four 3/8" x 1 1/4" HH cap screws, lockwashers and hexnuts (Part #26, 32 & 35).
5. Next the joystick handle bracket (Part #4) must be attached to the joystick cable control kit (Part #3) with two 5/16" x 3 1/2" HH cap screws, lockwashers, hexnuts and flatwasher (Part #25, 31, 29, 29 & 34), if joystick needs a 1/4 turn remove two sleeves for the bolts from joystick and reinsert them at a 1/4 turn. Then attach this assembly to the handle bracket adapter plate (Part #5) with three 3/8" x 1 1/4" HH cap screws, lockwashers, hexnuts and one flatwasher (Part #26, 32, 30 & 35). Note: Attach all fasteners loosely to allow for desired adjustment later.
6. Then custom fit the handle bracket adapter plate (Part #5) onto the fender wall just ahead of the side counsel in the cab of the tractor. (For non-cab tractors it may require further customizing to fit.) Attach with two 3/8" x 1 3/4" HH cap screws, lockwashers and hexnuts (Part #27, 32 & 35). You will need to route the cable ends down through the access hole in the cab floor just ahead of the side counsel. Adjust the according brackets to acquire the most desirable position for the joystick handle. **See in Fig. 1-2.**
7. When this has been done attach the cable ends to the valve body with the connector kits (Part #6). **Note: Make sure the joystick is in the locked position.** (Center the joystick and push the joystick knob in (located on the side of joystick) to lock joystick.) First screw the nut on to the cable then put the small o-ring on the cable past the threads. Slide large o-ring on the connector and thread the cable connector and slide the valve controller on the cable. Now thread the small nut and the pin connector onto the cable and tighten. Make sure the end of the cable does not hit the valve push rod. Now push pin connector onto the valve push rod and slide the pin through the holes. Thread the cable connector to the valve by hand. **Note: Only hand tighten the valve connector, if over tighten the joystick will not be right.** Now push large o-ring



Fig 1-1



Fig 1-2

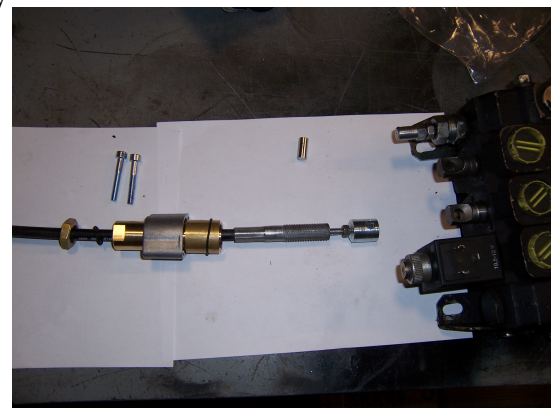
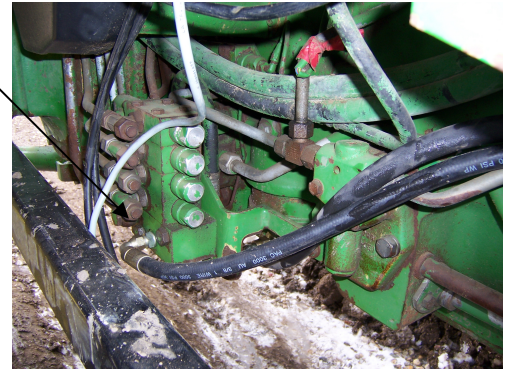

Fig 1-3

to the valve into the groove of cable connector. Then slide the valve connector to the valve and bolt together with given Allen head bolts. Slide the small o-ring to cable connector groove on the end and thread the large nut to cable connector and tighten.

Note: Make sure the cable connector does not move. See in Fig. 1-3.

Pressure



8. Route the pressure 58" hose (Part #16) to the pressure port on the valve and to the valve on the tractor. See instruction sheet for proper connections. **See in Fig. 1-4.**
9. Route the return 48" hose (Part #15) to the filter on the tractor. See instruction sheet for proper connections. **See in Fig. 1-5.**
10. Next put the bulk head adapters and the male half (Part #9) on the mid-mount couple plate (Part #18). Note: At this point install the female half of the colored plugs (Part #7) along with the couplers. **See in Fig. 1-6.**
11. Install the mid-mount couple plate (Part #18) to mount with two 3/8" x 1 1/4" HH cap screws, lock washers and hex nuts (Part #26, 32 & 35).
12. Route the 30" hoses (Part #14) to the proper bulkheads on the mid-mount couplers already installed on the loader mount of the tractor. See instruction sheet for proper connections.
13. After this has been done attach the female half of the quick coupler (Part #8) onto the 72" hoses (Part #17). Note: At this point install the male half of the colored plugs (Part #7). Attach the other end of the hoses to the steel oil lines on the loader frame. Refer to the top view of the working port diagram and the loader manual to determine the function of the port.
14. Secure hoses together with the 36" of hose wrap and nylon ties to make sure they do not interfere with any tractor function.
15. Finally start the tractor, actuate the loader to charge the hydraulic system with oil and add hydraulic fluid to the tractor as required using the recommended fluid for your tractor. Refer to the hydraulic section of the tractor owner's manual for the specific details regarding hydraulic fluid levels.

Fig 1-4

Return



Fig 1-5

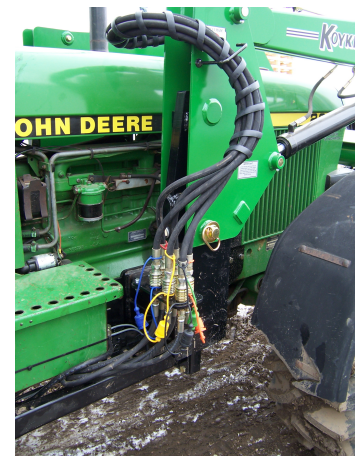
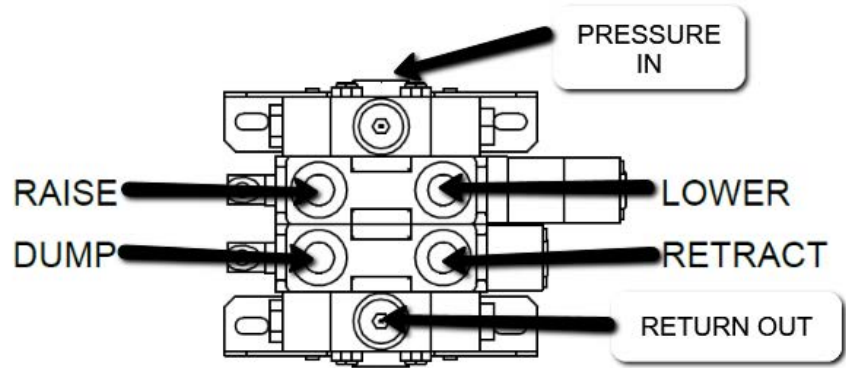

Fig 1-6

2 SPOOL LOAD SENSING/CLOSED CENTER VALVE
PORTS LABELED



LOAD SENSE IN /
PLUG FOR CLOSED
CENTER

3 SPOOL LOAD SENSING/CLOSED CENTER
VALVE PORTS LABELED

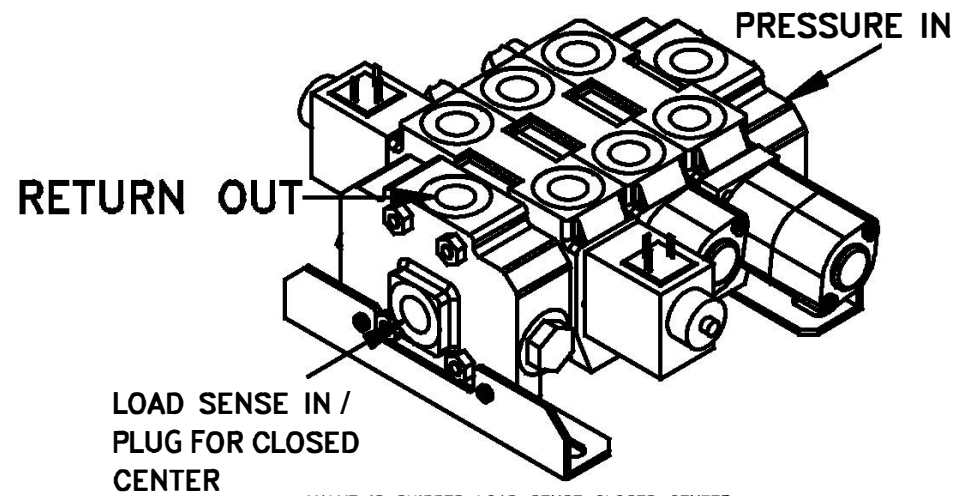
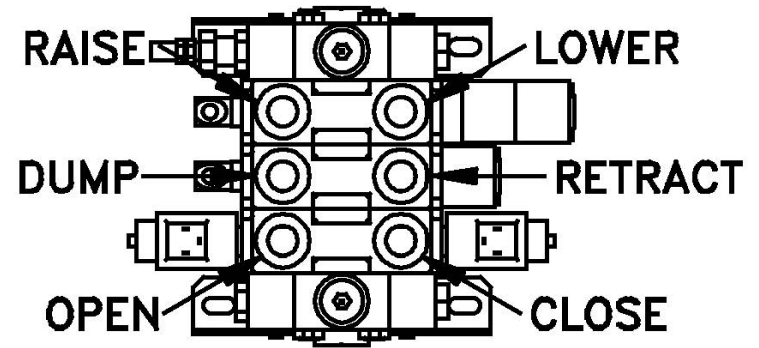

VALVE IS SHIPPED LOAD SENSE CLOSED CENTER.

VIDEOS:

CONNECTING CABLES TO VALVE:

<https://youtu.be/AOKy1CnuU4o>



CONNECTING CABLES TO JOYSTICK:

<https://youtu.be/vbcYCtpPtaw>

